

FEATURES

- TFT-Active Matrix-LCD Drive System
- 234 (V) × 479 (H) Dots (Total 112,086) (Delta Configuration)
- Slim, lightweight and compact:
 - Active Area/Outline Area: 53%
 - Thickness: 20.7 mm
 - Weight: 180 g
- Built-in video interface circuit (including chroma demodulator, picture tone, video AGC circuit) and control circuit responsive to composite video signal
- Also responsive to standard analog RGB video signals
- Further RGB signals can be superimposed on composite video signal (in this case, RGB signals shall be digital input signal for eight-color displays)
- High-quality full-color rendition with backlight source incorporated
- Viewing angle:
 - 6 o'clock direction: LQ4NC01
 - 12 o'clock direction: LQ4NC02

DESCRIPTION

The SHARP LQ4NC01/LQ4NC02 Color TFT-LCD module is an active matrix LCD (Liquid Crystal Display) produced by making the most of SHARP's expertise in liquid-crystal and semiconductor technologies. The active device is amorphous silicon Thin Film Transistor (TFT). The module accepts full-color video signals (composite video and analog RGB) conforming to the NTSC (M) system standard.

When additionally provided with the backlight-driving DC/AC inverter, it is applicable to pocket TVs and various display monitors.

The module consists of a TFT-LCD panel, driver ICs, control PWB mounted with electronic circuits, fluorescent tube, reflector, frame, front and rear shielding cases.

NOTE: Backlight-driving DC/AC inverter is not built into the module.

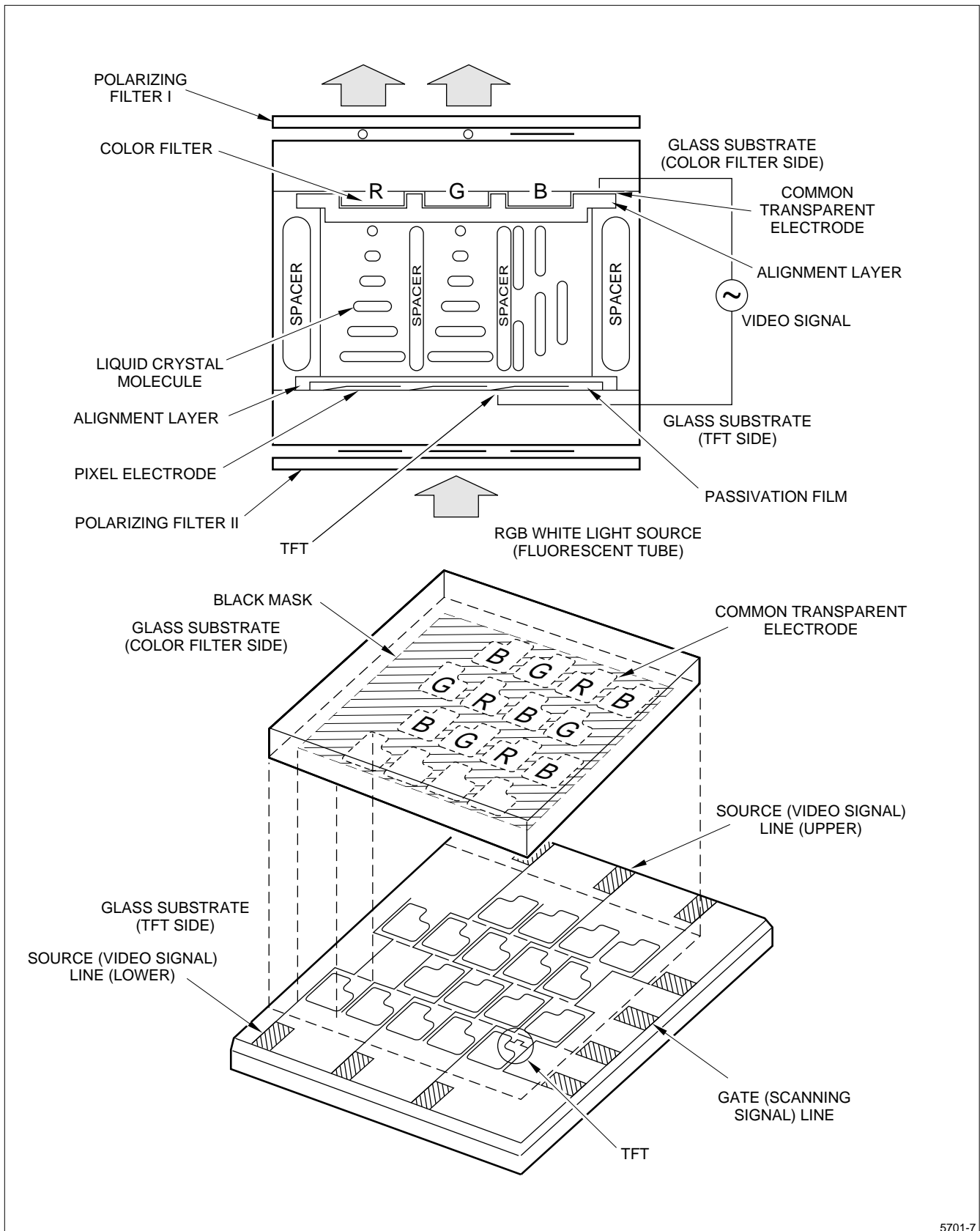

5701-7

Figure 1. LQ4NC01/LQ4NC02 TFT-LCD Panel

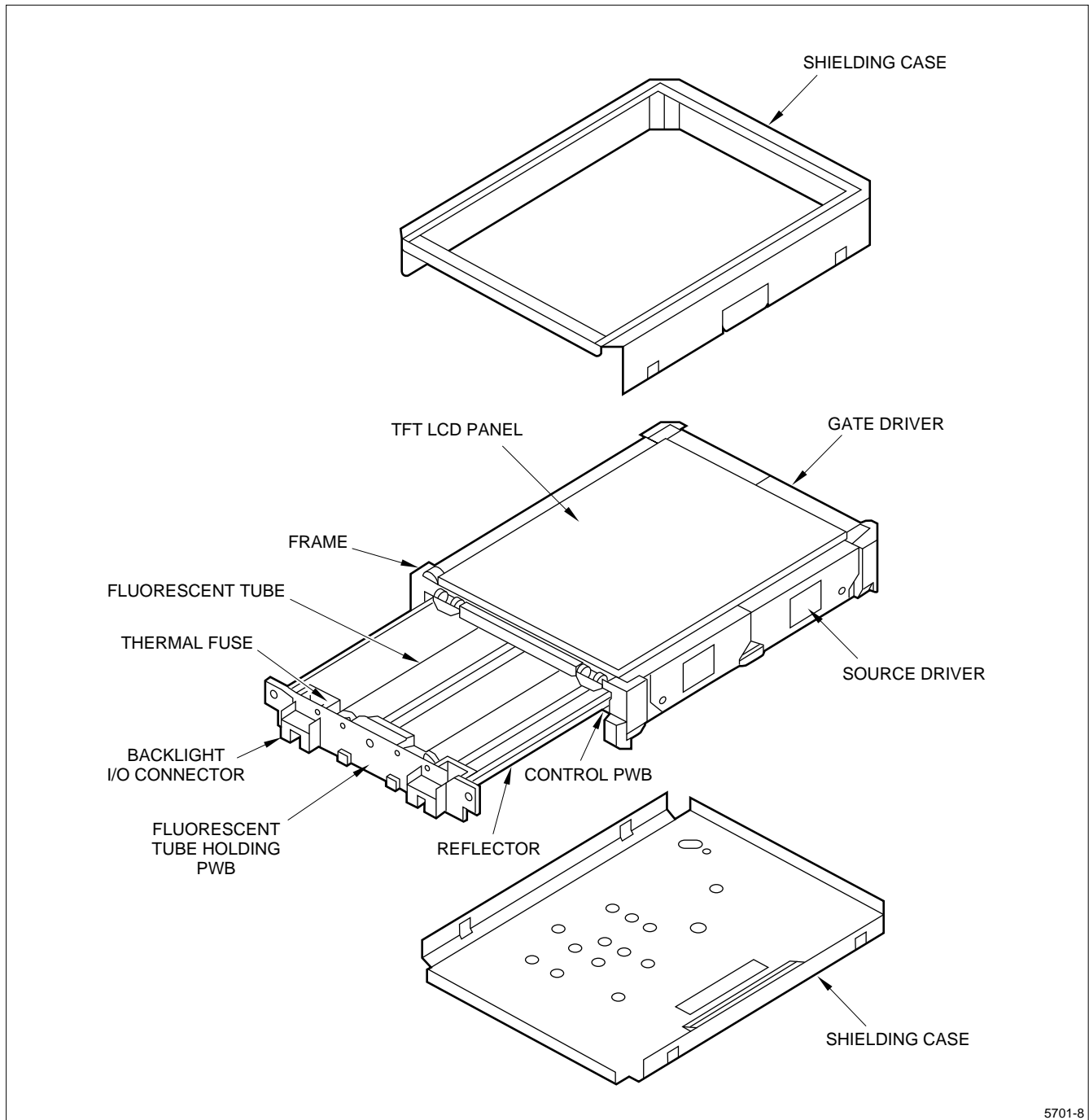

5701-8

Figure 2. LQ4NC01/LQ4NC02 TFT-LCD Module Construction

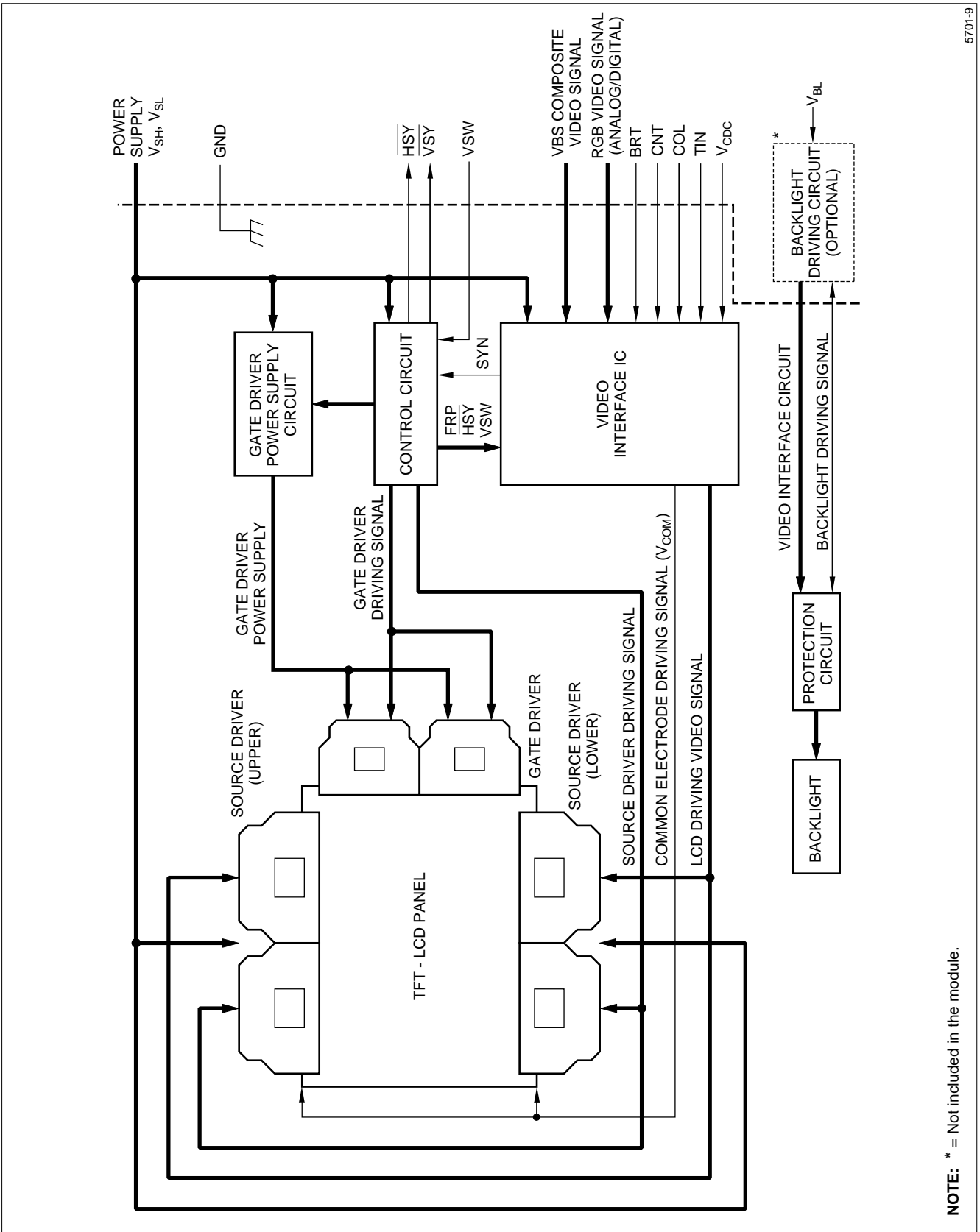

Figure 3. LQ4NC01/LQ4NC02 Block Diagram

MECHANICAL SPECIFICATIONS

PARAMETER	SPECIFICATIONS	UNIT	NOTE
Display Format	479 (W) × 234 (H)	dots	–
Active Area	81.9 (W) × 61.8 (H)	mm	–
Screen Size	4 (Diagonal)	inch	–
Dot Pitch	0.171 (W) × 0.264 (H)	mm	–
Dot Configuration	RGB Delta Configuration	–	–
Outline Dimensions	110.2 (W) × 85.8 (H) × 20.7 (D)	mm	1
Weight	180 ±10	g	–

NOTE:

1. Excludes protrusions.

**ABSOLUTE MAXIMUM RATINGS – TFT-LCD
PANEL DRIVING SECTION (GND = 0 V, t_A = 25°C)**

SYMBOL	PARAMETER	MIN.	MAX.	UNIT	NOTE
V _{SH}	Positive Power Supply Voltage	–0.3	+6.0	V	–
V _{SL}	Negative Power Supply Voltage	–9.0	+0.3	V	–
V _{i1}	Video Input Signal 1	–	2.0	V _{P-P}	1
V _{i2}	Video Input Signal 2	–	V _{SH} – 0.3	V _{P-P}	2
V _I	Digital Input/Output Signals	–0.3	V _{SH} + 0.3	V	3
V _{CDC}	DC Bias Voltage of Common Electrode Driving Signal	V _{SL} – 0.3	–1.5	V	–
V _{PIC}	Picture Adjusting Terminal Voltage	–0.3	V _{SH} – 0.3	V	4
t _{STG}	Storage Temperature	–25	60	°C	5
t _{OPP}	Operating Temperature – Panel Temperature	0	60	°C	
t _{OPA}	Operating Temperature – Ambient Temperature	0	40	°C	

NOTES:

1. VBS terminal (composite video signal).
2. VRI, VGI, VBI terminals (RGB signals).
3. $\overline{\text{HSY}}$, $\overline{\text{VSX}}$, VSW terminals.
4. BRT, CNT, COL, TIN terminals.
5. Maximum wet-bulb temperature 38°C or less. No dew condensation.

ABSOLUTE MAXIMUM RATINGS – BACKLIGHT DRIVING SECTION (t_A = 25°C)

SYMBOL	PARAMETER	MIN	MAX	UNIT
V _F	Filament Voltage	–	8.5	V _{RMS}

INPUT/OUTPUT TERMINALS – TFT-LCD PANEL DRIVING SECTION

PIN NUMBER	SYMBOL	I/O	DESCRIPTION	NOTE
1	$\overline{\text{HSY}}$	O	Internal Horizontal Sync Signal (In phase with VBS)	–
2	$\overline{\text{VS Y}}$	O	Internal Vertical Sync Signal (In phase with VBS)	–
3	TST	–	This is Electrically Opened During Operation	–
4	NC	–		
5	TST	–		
6	GND	I	Ground	–
7	VSW	I	Selection Signal of Two Sets of Video Signals	1
8	GND	I	Ground	–
9	V_{CDC}	I	DC Bias Voltage Adjusting Terminal of Common Electrode Driving Signal	2
10	VSH	I	Positive Power Supply Voltage	–
11	VBS	I	Composite Video Signal	3
12	BRT	I	Brightness Adjusting Terminal	4
13	CNT	I	Contrast Adjusting Terminal	
14	COL	I	Color Gain Adjusting Terminal	
15	TIN	I	Tint Adjusting Terminal	
16	VSL	I	Negative Power Supply Voltage	–
17	VRI	I	Color Video Signal – Red	5
18	VGI	I	Color Video Signal – Green	
19	VBI	I	Color Video Signal – Blue	
20	GND	I	Ground	–

NOTES:

In the following descriptions, 'High' means 'V_{SH}' and 'Low' means 'GND.'

- Selects input signals, composite or RGB:
 - When VSW is 'High' or open, composite video signal (Pin Number 13) is selected.
 - When VSW is 'Low,' RGB signal set (Pins Number 17 through 19) is selected.
- Common electrode driving signal (V_{COM}) generated in the module is observed on the pin. It should be opened during operation, since the DC component of V_{COM} (V_{CDC}) is adjusted to the optimum value with V_{SH} and V_{SL} as the typical value on shipping. If the optimum value changes (for example, lowering of the power source), it should be readjusted using the built-in variable resistor (V_{CDC}) or external circuit shown in Figure 5. Refer to 'Adjusting Method of Optimum Common Electrode DC Bias Voltage' to readjust.
- Similarly, for RGB input, apply composite video signal or composite sync signal (with negative polarity) for sync separator.
- Brightness, contrast, color gain, and tint are adjusted by the DC voltage supplied to each pin. (Contrast, color gain, and tint are not available for RGB signal input). They are adjusted to the optimum value on shipping, but they can be readjusted using the built-in variable resistor (BRT, CNT, COL, TIN) or external circuit shown in Figure 5. (However, since contrast is adjusted to maximize display characteristics, it should not be readjusted, and keep outer adjustment terminals open.)
- Responsive to 0 to 0.7 $V_{\text{P-P}}$ analog RGB signal when VSW is fixed to 'Low.'
 - For superimposing on composite video signal in the case of screen display (refer to Note 1), RGB signals are digital signals (Low: 0 $V_{\text{P-P}}$, High: > 2 $V_{\text{P-P}}$ available for eight-color display).

INPUT/OUTPUT TERMINALS – BACKLIGHT DRIVING SECTION

PIN NUMBER	SYMBOL	I/O	DESCRIPTION	NOTE
L1	VBL1	I	Input for Thermal Fuses	1
L2	NC	–	No Connection	–
L3	VF1	I	Power Supply for Fluorescent Tube Filament (1)	–
L4	VF2	I		2
L5	VF3	I	Power Supply for Fluorescent Tube Filament (2)	–
L6	VF4	I		–
L7	NC	–	No Connection	–
L8	VBL2	O	Output From Thermal Fuses	1

NOTES:

1. Thermal fuses are connected between the L1 and L8 terminals in the backlight unit. When connected with the input power line of DC/AC inverter for backlight, the terminals can protect the backlight unit against excessive temperature rise at the lamp electrodes.
2. Should be grounded by the backlight driving DC/AC inverter, since the L4 terminal is connected with the reflector. It will be grounded by the optional DC/AC inverter. For internal electrical connection of backlight unit, see Figure 4.

CAUTION: Shielding case is separated from GND terminal and electrically open.

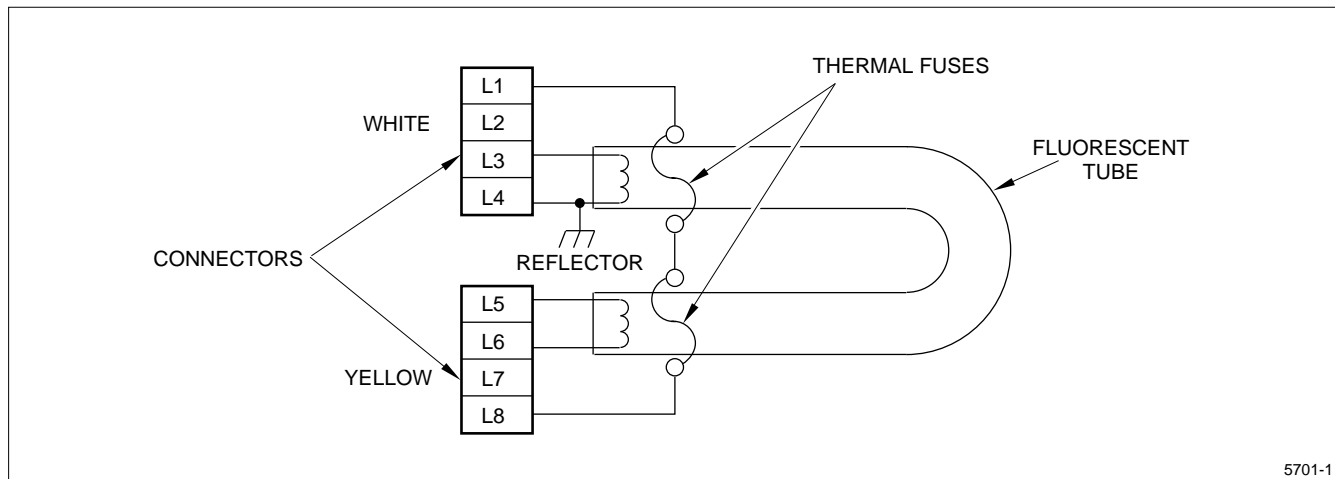

Figure 4. Wiring Diagram of Backlight Unit

RECOMMENDED OPERATING CONDITIONS – TFT-LCD PANEL SECTION**(GND = 0 V, $t_A = 25^\circ\text{C}$)**

SYMBOL	PARAMETER	MIN	TYP	MAX	UNIT	NOTE
V_{SH}	Positive Power Supply Voltage	+4.8	+5.0	+5.2	V	–
V_{SL}	Negative Power Supply Voltage	–7.6	–8.0	–8.4	V	–
VBS	Video Input Signal Amplitude (Peak Level)	0.7	1.0	1.3	V_{P-P}	1
V_{RGB} (1)		–	0.7	–	V_{P-P}	2
V_{RGB} (2)		2.0	–	4.0	V_{P-P}	3
V_{IOC}	Video Input Signal DC Component	–1.0	0	+1.0	V	4
V_{IH}	Digital Input Voltage – High Level	+3.5	–	V_{SH}	V	5
V_{IL}	Digital Input Voltage – Low Level	0	–	+1.5	V	–
V_{OH}	Digital Output Voltage – High Level	+3.5	–	V_{SH}	V	6
V_{OL}	Digital Output Voltage – Low Level	0	–	+1.5	V	–
V_{CDC}	DC Bias Voltage of Common Electrode Driving Signal	–4.5	–3.5	–2.5	V	7

NOTES:

1. VBS (composite video signal). Input impedance: 75 Ω . Amplitude of sync signal: >0.2 V_{P-P} .
2. VRI, VGI, VBI terminals (RGB signals for analog display). Input impedance: >10 k Ω .
3. VRI, VGI, VBI terminals (RGB signals for superimposing). Input impedance: >10 k Ω .
4. VBS, VRI, VGI, VBI terminals.
5. VSW terminal. Input impedance: >50 k Ω .
6. \overline{HSY} , $\overline{VS\overline{Y}}$ terminals (internal sync signals). Load resistance: >20 k Ω .
7. Adjusted for each module so as to attain maximum contrast ratio. Refer to 'Adjusting Method of Optimum Common Electrode DC Bias Voltage' for adjusting.

RECOMMENDED OPERATING CONDITIONS – BACKLIGHT DRIVING SECTION ($t_A = 25^\circ\text{C}$)

SYMBOL	PARAMETER	MIN	TYP	MAX	UNIT	NOTE
V_L	Lamp Voltage	95	110	125	V_{RMS}	Just for reference
I_L	Lamp Current	13	15	18	mA_{RMS}	
V_F	Filament Voltage	6.0	6.5	7.0	V_{RMS}	
I_F	Filament Current	58	66	74	mA_{RMS}	
f_L	Frequency	20	–	50	kHz	–
V_S	Kick-Off Voltage	600	–	–	V_{RMS}	Note 1

NOTE:

1. The reflector should be grounded.
DC/AC inverter for driving hot cathode fluorescent tube (HCFT) is not built into the module.
DC/AC inverter for external connection (Model Number LQ0J06) is optionally available.

POWER CONSUMPTION ($t_A = 25^\circ\text{C}$)

SYMBOL	PARAMETER	CONDITION	MIN	TYP	MAX	UNIT	NOTE
I_{SH}	Power Consumption by the Panel Section	Positive Supply Current	–	+90	+115	mA	–
I_{SL}		Negative Supply Current	–	–55	–80	mA	–
W_S		Total	–	0.89	1.22	W	1
W_L	Power Consumption by the Fluorescent Tube Section	On rated lighting	–	1.7	2.3	W	2

NOTES:

1. Excludes power consumption by the backlight.
2. Calculated reference value ($I_L \times V_L$).

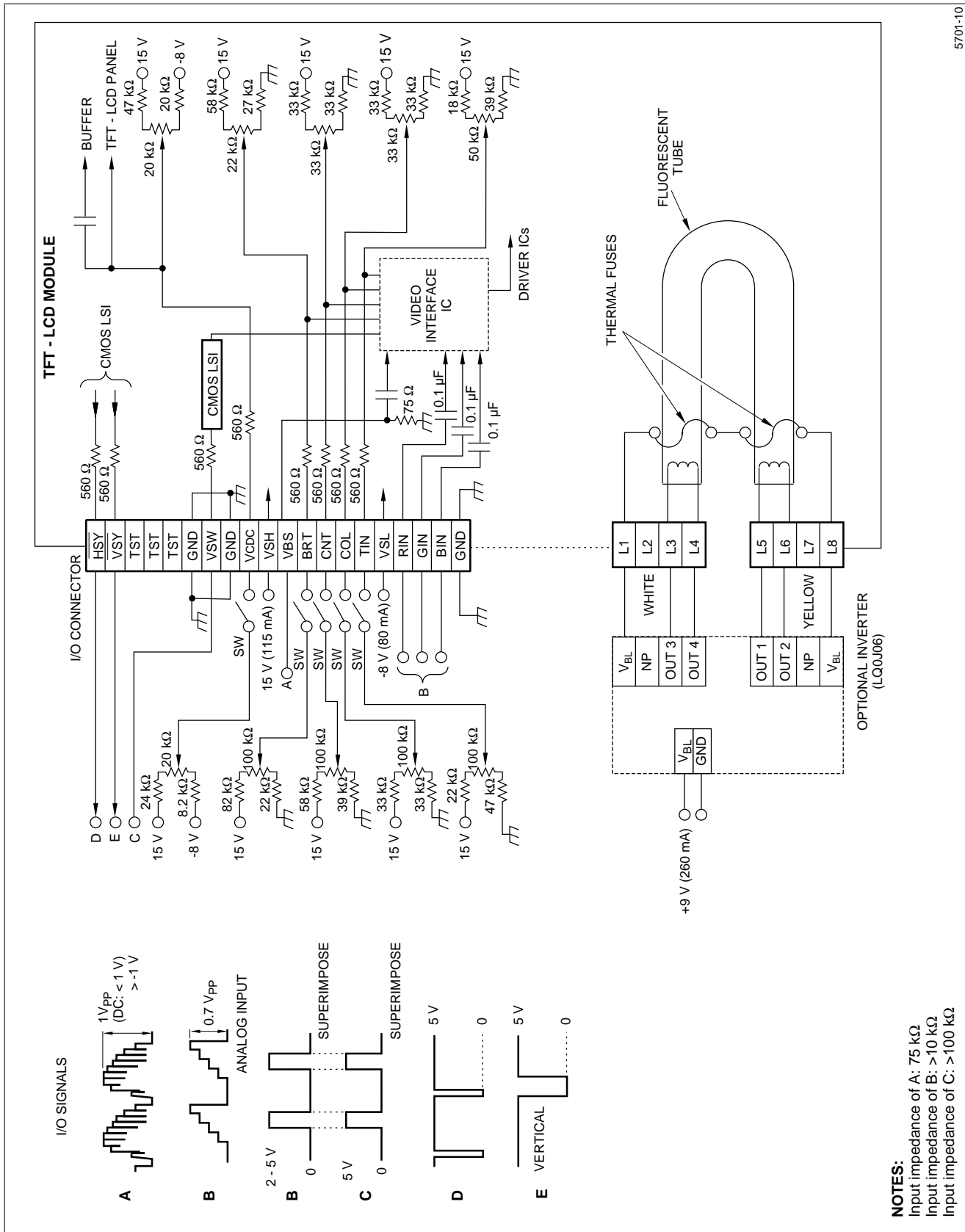
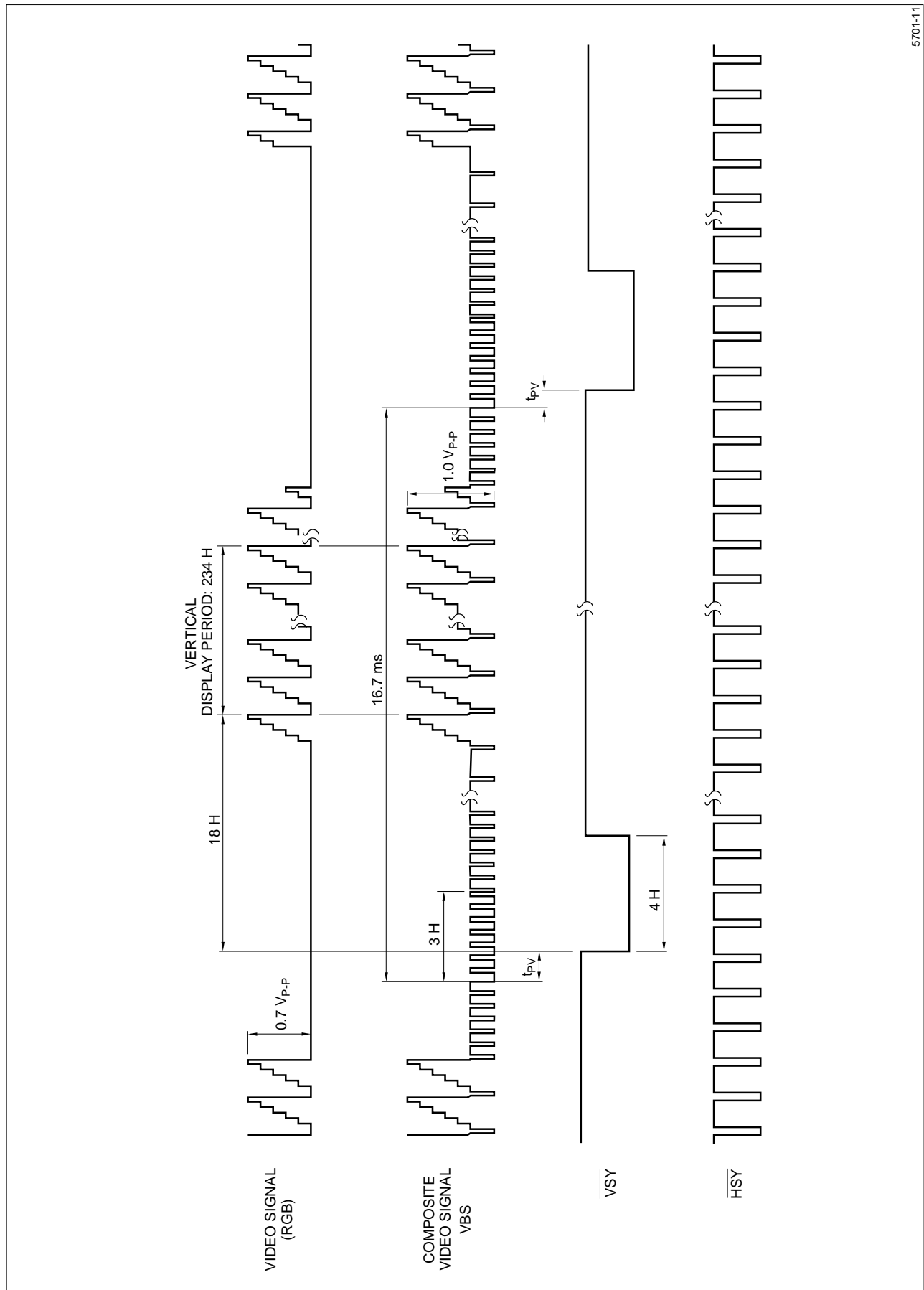

Figure 5. Recommended Circuit for TFT-LCD Module



5701-11

Figure 6. Input/Output Signal Waveforms

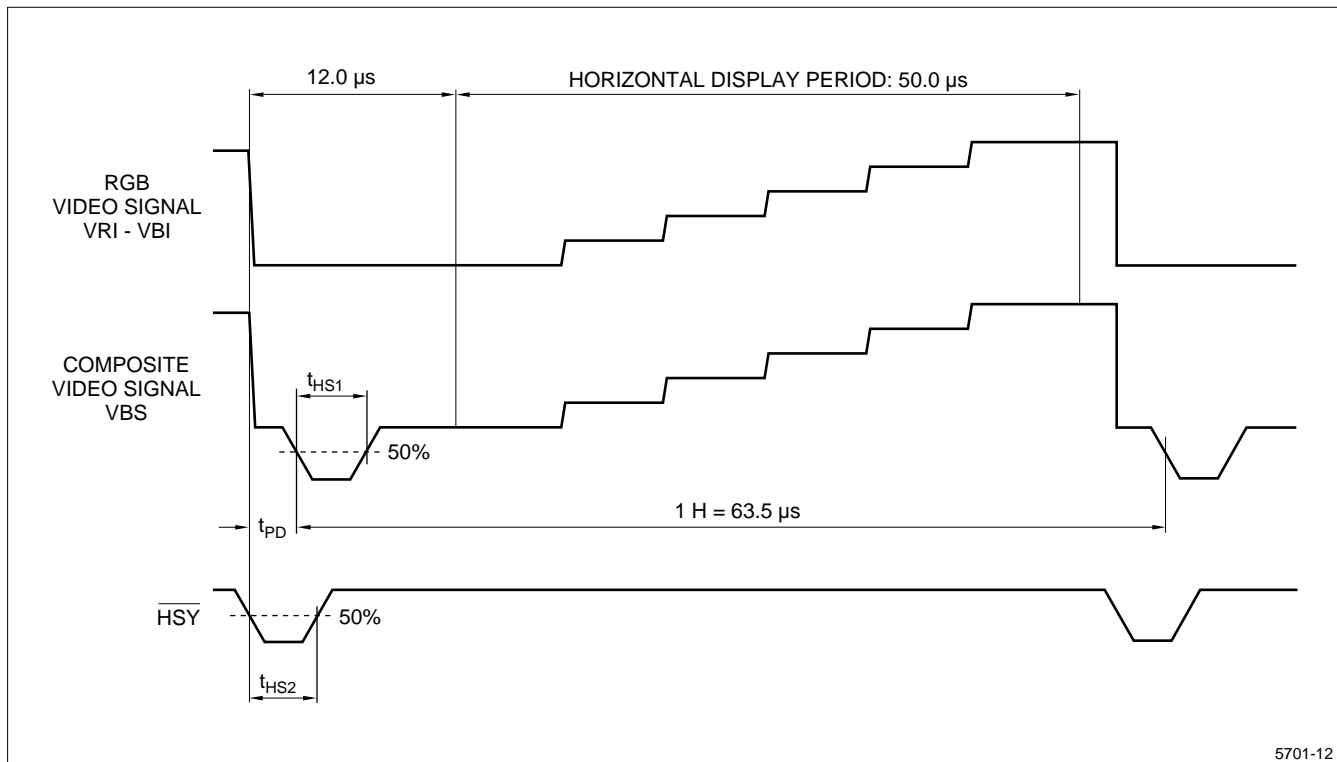

Figure 7. Input/Output Signal Timing Chart

TIMING CHARACTERISTICS – INPUT/OUTPUT SIGNALS ($V_{SH} = +5\text{ V}$, $V_{SL} = -8\text{ V}$) ($f_H = 15.7\text{ kHz}$, $f_V = 60\text{ Hz}$)

SYMBOL	PARAMETER	CONDITION	MIN	TYP	MAX	UNIT	NOTE
t_{HS1}	Horizontal Sync – Input Pulse Width	–	4.2	4.7	5.7	μsec	–
t_{HS2}	Horizontal Sync – Output Pulse Width	$f = f_H$	2.3	4.7	7.1		1
t_{PD}	Horizontal Sync Phase Difference	–	-0.1	–	2.7		2
t_{VS}	Vertical Sync Output Pulse Width	$4/f_H$	243	256	269		–
t_{PV}	Vertical Sync Phase Difference	–	121/90	127/95	133/100		3

NOTES:

- Adjusted by variable resistor (H-POS).
- Variable range by variable resistor (H-POS).
(Positive when HSY proceeds VBS.)
Adjusted value: $t_{pd} = 1.3 \pm 0.7\text{ μs}$.
- Odd field/Even field ($2/f_H$ / $1.5/f_H$).

Display Time Range

- Horizontally: 12.0 to 61.9 μs from the falling edge of \overline{HSY} .
- Vertically: 19 to 252 H from the falling edge of \overline{VSY} .

OPTICAL CHARACTERISTICS

SYMBOL	PARAMETER	CONDITION	MIN	TYP	MAX	UNIT	NOTE
$\Delta\theta 11$	Viewing Angle Range	$CR \geq 10$	30 (10)	–	–	degrees	LQ4NC01 (LQ4NC02) 1, 2
$\Delta\theta 12$			10 (30)	–	–		
$\Delta\theta 2$			45	–	–		
CR_{MAX}	Contrast Ratio	$\theta = 0^\circ$	30	–	–	–	2, 3
t_R	Response Time – Rise	$\theta = 15^\circ$	–	30	–	ms	2
t_D	Response Time – Decay		–	50	–	ms	4
Y_L	Brightness	–	100	120	–	nt	5
K_L	Color Temperature	$\theta = 0^\circ$	–	7900	–	K	5
x	White Chromaticity		0.247	0.297	0.347	–	
y			0.262	0.312	0.362	–	

NOTES:

- Viewing angle range is defined in Figure 8.
- Applied voltage for measuring optical characteristics:
 - V_{DC} must be adjusted by the Flicker measuring method or the Contrast measuring method described in 'Adjusting Method of Optimum Common Electrode DC Bias Voltage.'
 - Brightness adjusting terminal (BRT) should be opened.
 - Video signal of reference black level and 100% white level must be input.
- Contrast ratio is defined as follows:
Contrast ratio is calculated with the following formula in the optical characteristics measuring method shown in Figure 10:

$$\text{Contrast ratio (CR)} = \frac{\text{Photodetector output with LCD being 'white'}}{\text{Photodetector output with LCD being 'black'}}$$
- Input signals are applied to the area measured to make the area 'white' and 'black' respectively, and change with time in the photodetector output is measured in the optical characteristics measuring method shown in Figure 10.
- Measured on the center area of the panel at the viewing cone 1° by TOPCON luminance meter BM-7.

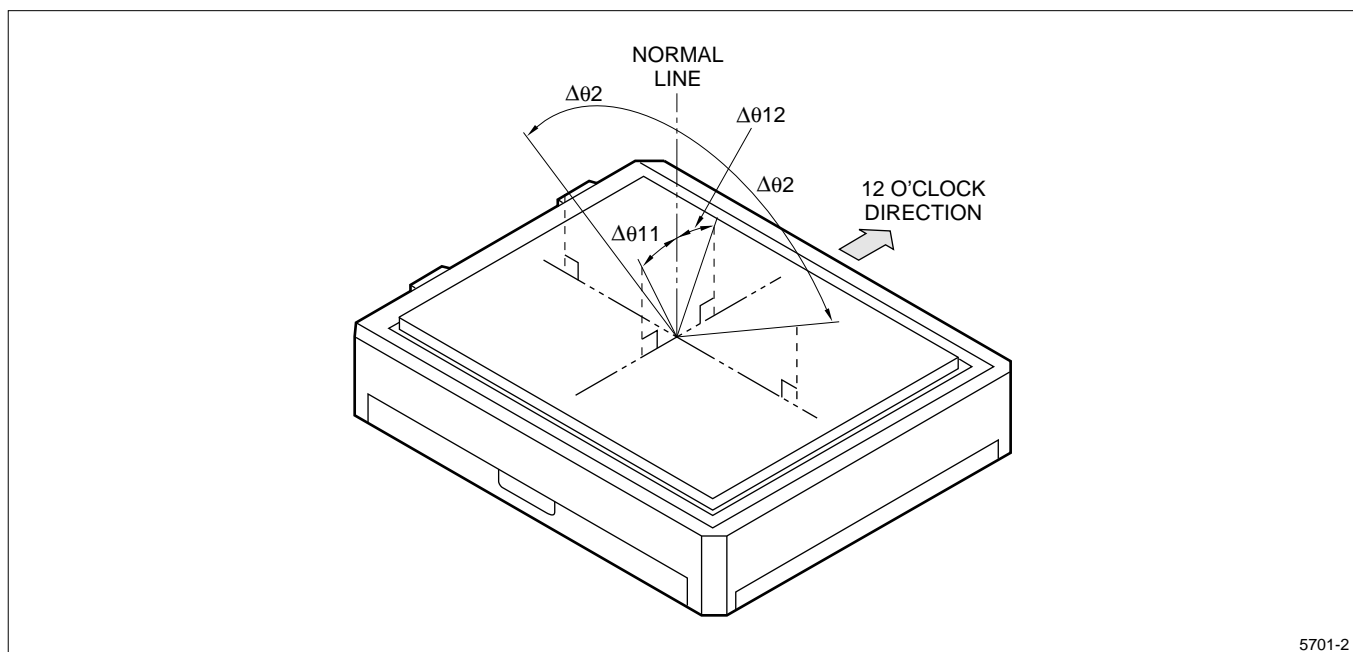
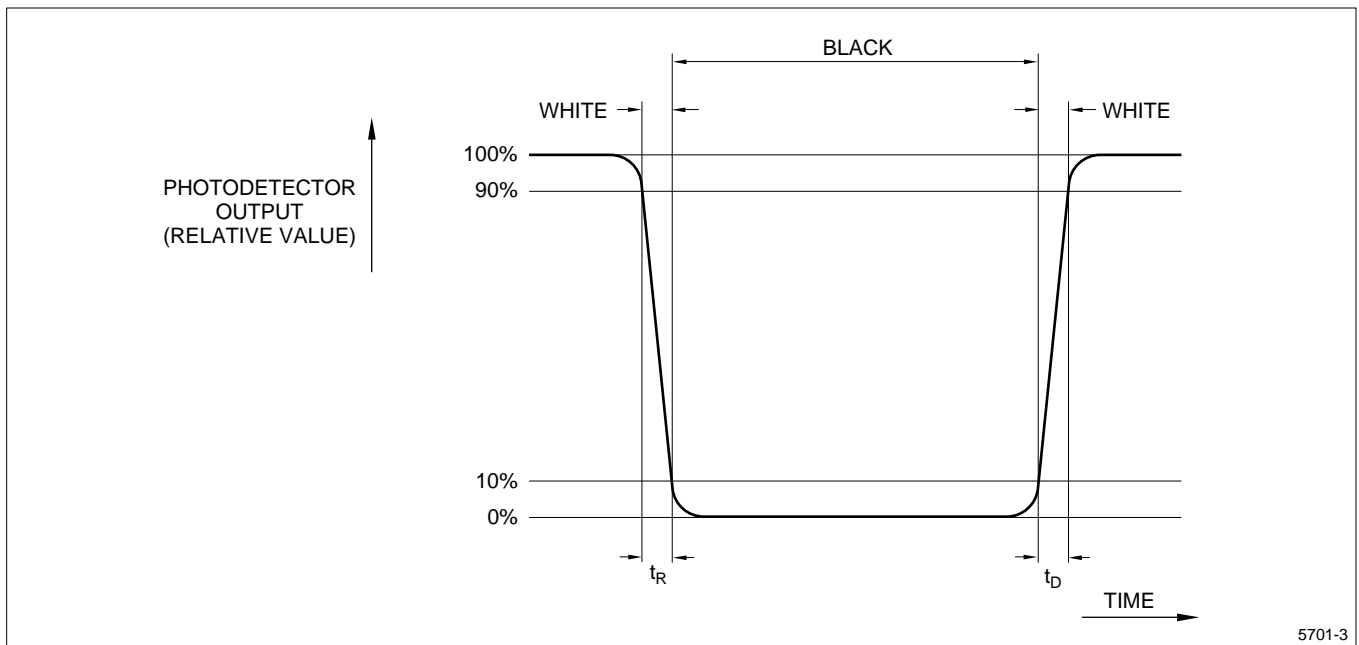
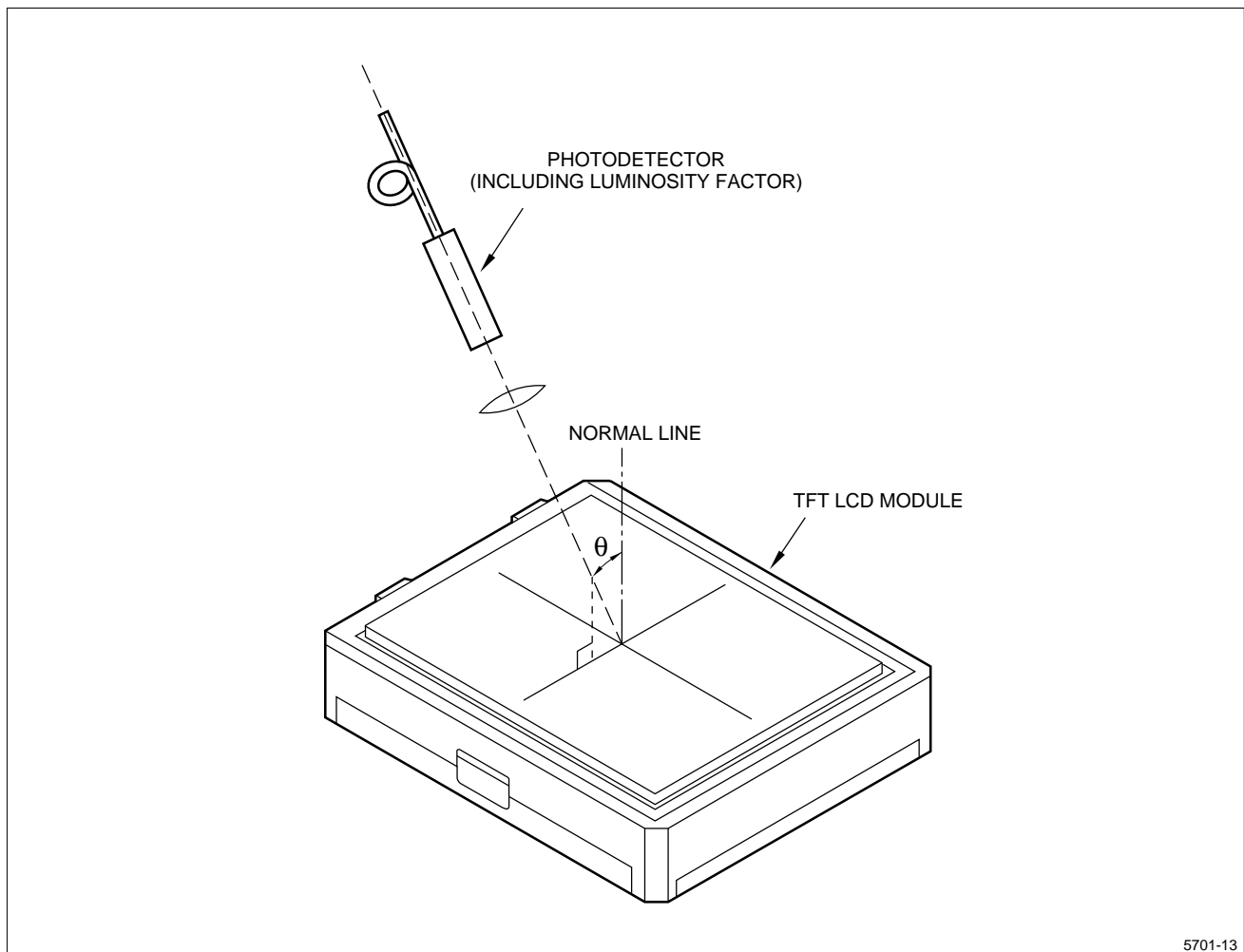

Figure 8. Definition of Viewing Angle Range



5701-3

Figure 9. Definition of Response Time



5701-13

Figure 10. Optical Characteristics Measuring Method

MECHANICAL CHARACTERISTICS

External Appearance

There will not be any conspicuous defects. (See Outline Dimensions diagram.)

Panel Durability

The panel will not break when the panel center is pressed with a 2 kg force by a 15 mm diameter smooth flat surface.

CAUTION: The least force can cause functional troubles if it is applied on the active area for a long time.

Maximum Resin Region

As shown in Figure 11, resin may fill up to the same level as a line connecting the upper ridges of a panel and a shielding case.

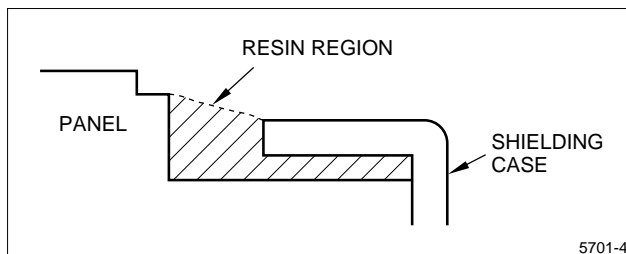

Figure 11. Maximum Resin Region

I/O Connector Performance

I/O connector of LCD panel driving circuit (FPC connector 20 pins):

- Applicable FPC: Shown in Figure 12.
- Terminal holding force: 100 g or larger/pin. (Each terminal is pulled out at a rate of 25 ± 3 mm/minute).
- Insertion/pulling durability: Contact resistance not larger than double the initial value after applicable FPC is inserted and pulled out 20 times.

I/O Connector of Backlight Driving Circuit (PH Connector 4 Pins X 2 Pieces)

- Applicable connector housing: PHR-4 (produced by Japan Solderless Terminal).
- Terminal holding force: 100 g or more/pin. (Pulled out at a rate of 1 through 5 mm/second).
- Insertion/pulling durability: Contact resistance not larger than double the initial value after connectors are inserted and pulled out 20 times.

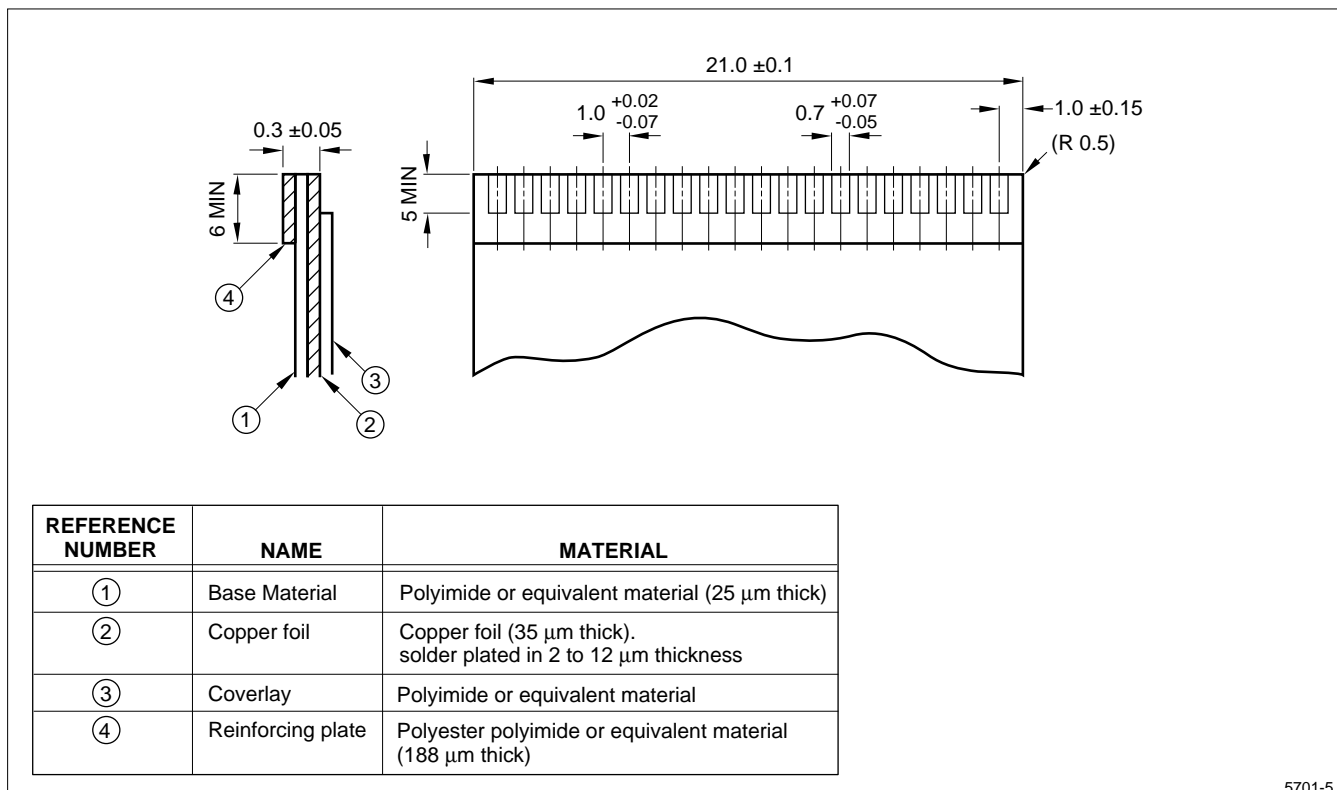

5701-5

Figure 12. Applicable FPC For I/O Connector (1.0 mm pitch)

DISPLAY QUALITY

The display quality of the color TFT-LCD module shall be in compliance with the Delivery Inspection Standard (Separate Sheet LDI-89901).

HANDLING INSTRUCTIONS

Mounting of Module

The TFT-LCD module is designed to be mounted on equipment using the mounting tabs in the four corners of the module rear face. When mounting the module, it is recommended to use the M2.6 tapping screw (fastening torque is 5 through 6 kg•cm). Be sure to fix the module on the same plane, taking care not to warp or twist the module.

Precautions in Mounting

- The polarizer is made of soft material and susceptible to flaws. Handle carefully. Protective film (laminator) is applied on the surface to protect it against scratches and dirt. Remove the laminator just before using to avoid static electricity.
- Use cautions when removing the laminator.

Precautions When Peeling off the Laminator

Working Environment

When the laminator is removed, static electricity may cause dust to stick to the polarizer surface. To avoid this, the following working environment is desirable:

- Floor: Conductive treatment of 1 MΩ or more on the tile or a conductive mat or conductive paint on the tile.
- Clean, dust-free room with an adhesive mat placed in the doorway.
- Humidity: 50% to 70% RH.
- Workers shall wear conductive shoes, conductive work clothes, conductive gloves, and a ground strap.

Working Procedures

- Direct the wind of the heat-ionized air-discharging blower somewhat downward to ensure that the module is blown sufficiently. Keep the distance between the module and the discharging blower within 20 cm (see Figure 13a).
- Attach adhesive tape to the laminator part near the discharging blower to protect polarizer against flaws (see Figure 13b).
- Peel off laminator, pulling adhesive tape slowly to your side, taking five or more seconds.
- After peeling off the laminator, pass the module to the next work process immediately without getting the module dusty.

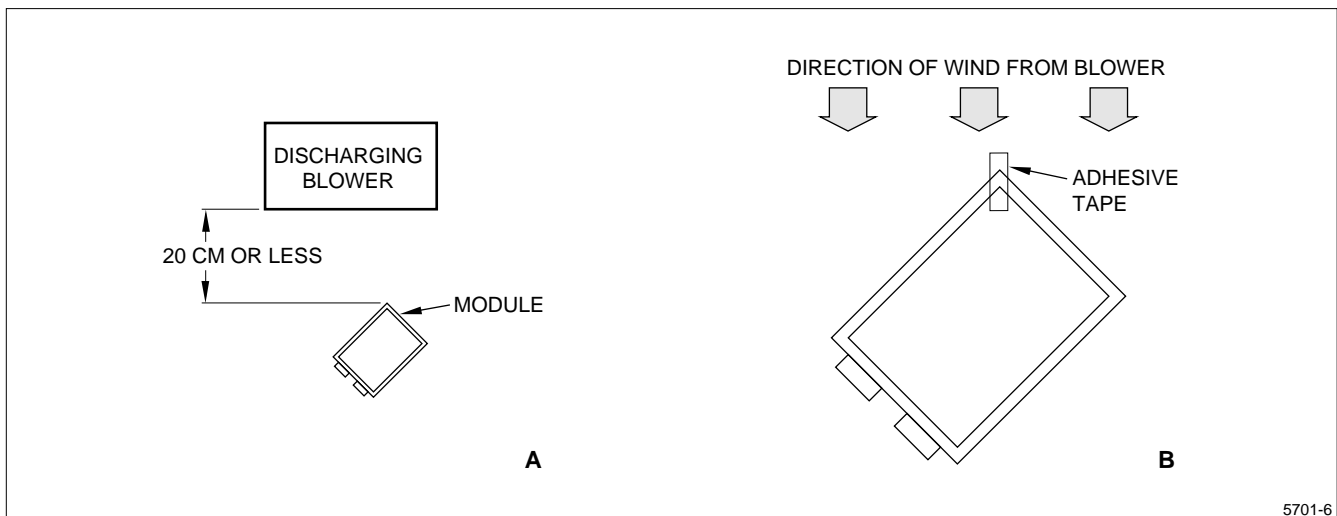

Figure 13. Proper Use of Discharging Blower

5701-6

- Methods to remove dust from polarizer:
 - Blow off dust with N₂ blower for which static electricity preventive measures have been taken. Using an ionized air gun (Hugle Electronics Co.) is recommended.
 - Since the polarizer is vulnerable, wiping should be avoided. If wiping is unavoidable, wipe it carefully with a lens cleaning cloth, breathing on it. 'Belleseime' (Kanebo, Ltd.) is desirable.
- When metal parts of the TFT-LCD module (shielding lid and rear case) are soiled, wipe them with a soft dry cloth. For stubborn dirt, wipe the part, breathing gently on it.
- Wipe off water drops or finger grease immediately. Prolonged contact with water may cause discoloration or spots.
- The TFT-LCD module is made of glass which breaks or cracks easily if dropped or bumped on hard surfaces. Handle with care.
- Since CMOS LSI is used in this module, avoid static electricity and ground your body when handling.
- Store the module at a temperature near room temperature. At lower than the rated storage temperature, liquid crystal solidifies, causing the panel to be damaged. At higher than the rated storage temperature, liquid crystal turns into isotropic liquid and may not recover.
- If the LCD panel breaks, there may be a possibility that the liquid crystal escapes from the panel. Since the liquid crystal is harmful, do not put it into the eyes or mouth. When liquid crystal sticks to hands, feet, or clothes, wash it out immediately with soap.
- Observe all other precautionary requirements in handling general electronic components.

SHIPPING REQUIREMENTS

The packing form is shown in Figure 14.

Carton Storage Conditions

- Number of layers of cartons in pile: 10 layers maximum.
- Environmental conditions:
 - Temperature: 0°C to 40°C.
 - Humidity: 60% RH or less (at 40°C). No dew condensation even at a low temperature and high humidity.
 - Atmosphere: Harmful gases such as acid and alkali which corrode electronic components and wires must not be detected.
 - Storage Period: Approximately three months.
 - Opening of Package: To prevent the TFT-LCD module from being damaged by static electricity, adjust the room humidity to 50% RH or higher and provide an appropriate measure for electrostatic grounding before opening the package.

Precautions in Adjusting Module

- Adjusting volumes on the rear face of the module have been set optimally before shipment. Therefore, do not change any adjusted values. If adjusted values are changed, the specifications described in this technical literature may not be satisfied.

Other Precautions

- Do not expose the module to direct sunlight or intensive ultraviolet rays for a prolonged time as liquid crystal is deteriorated by ultraviolet rays.

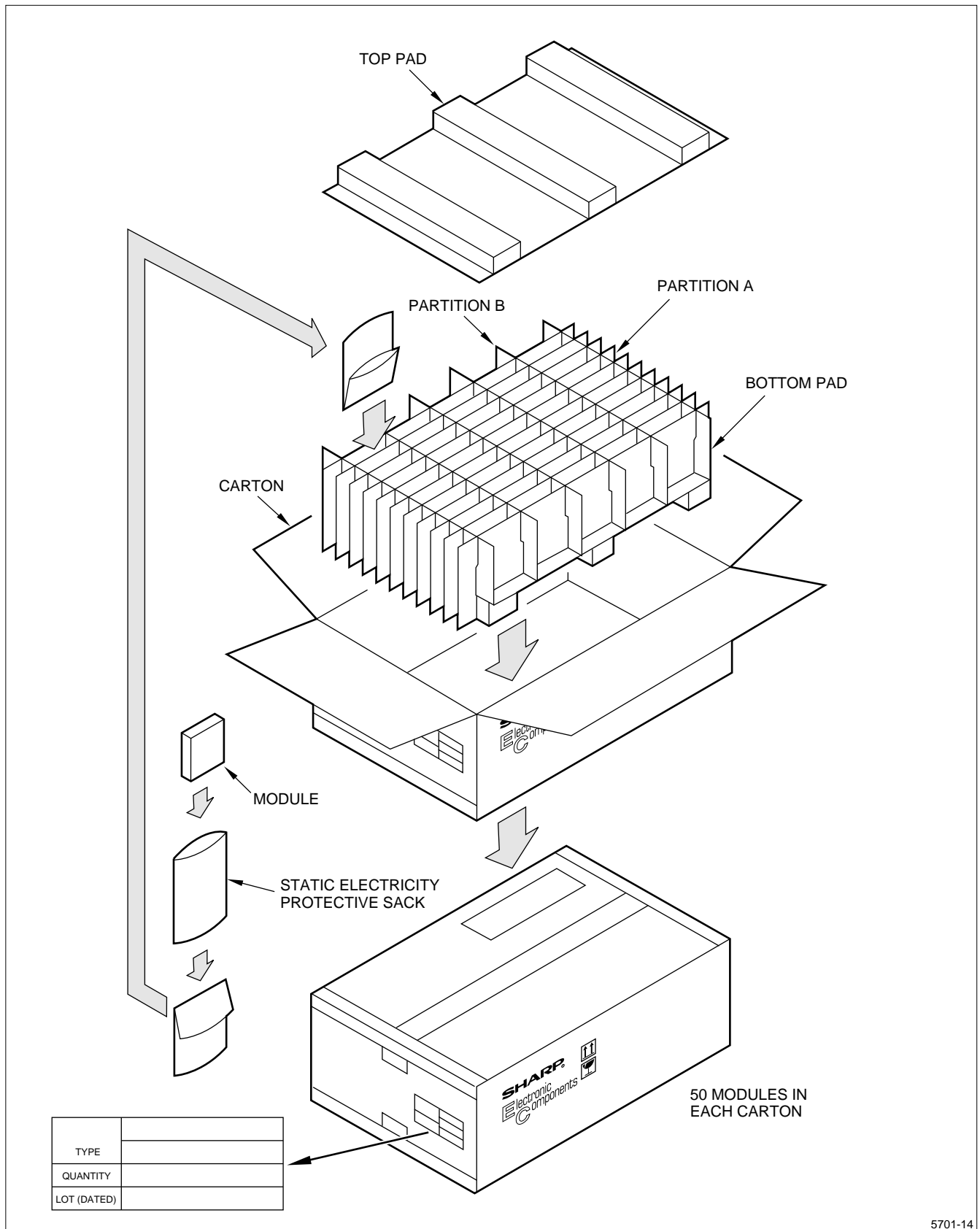

5701-14

Figure 14. Packing Form

RELIABILITY TEST ITEMS

NUMBER	TEST ITEM	CONDITIONS
1	High Temperature Storage Test	$t_A = 60^\circ\text{C}$, 240 H
2	Low Temperature Storage Test	$t_A = -25^\circ\text{C}$, 240 H
3	High Temperature and High Humidity Operating Test	$t_A = 40^\circ\text{C}$, 95% RH, 240 H
4	High Temperature Operating Test	$t_A = 40^\circ\text{C}$, 240 H
5	Low Temperature Operating Test	$t_A = 0^\circ\text{C}$, 240 H
6	Electrostatic Discharge Test	$\pm 200\text{ V}$, 200 pF (0 Ω), Once for each terminal
7	Shock Test	100 G, 6 ms, $\pm X$, $\pm Y$, $\pm Z$, three times for each direction (JIS C7021, A-7 Condition C)
8	Vibration Test	Frequency range: 10 to 55 Hz Stroke: 1.5 mm Sweep: 10 Hz to 55 Hz to 10 Hz Two hours for each direction of X, Y, Z (six hours in total) (JIS C7021, A-10 Condition A)
9	Heat Shock Test	-25°C to -60°C /5 cycles (2 hours/cycle) (1 H) (1 H)

Result Evaluation Criteria

Under the display quality test conditions with normal operation state, there shall be no change which may affect practical display function.

OTHER INFORMATION

If any problem should arise from this specification, the supplier and user should work out a mutually acceptable solution.

COCOM

This product falls under 'strategic product' according to the export trade control ordinance in force, and export of the item requires an export license issued by the related authorities.

Confirm with SHARP whether the license is necessary since the ordinance may be revised by the authorities.

CONSTRUCTION OF TFT-LCD MODULE

TFT-LCD module is composed of an LCD panel, driver ICs for the LCD panel, a control circuit for the driver ICs, a video signal processing circuit (video interface circuit) peculiar to the LCD, and a backlight.

The driver ICs are divided into two types: a source driver (data driver) which receives RGB signals and sends them sequentially by one horizontal line of the LCD panel, and a gate driver (scan driver) which scans 240 gate lines of the LCD panel.

The circuit diagram is shown in Figure 3.

The module displays an image on the LCD panel as it receives power supplies (V_{SH} , V_{SL}), composite video signal, RGB video signals, DC bias voltage of common electrode driving signal (V_{CDC}), selection signal of composite and RGB video signals (VSW), brightness adjusting DC voltage (BRT), color gain adjusting DC voltage (COL), tint adjusting DC voltage (TIN), and contrast adjusting DC voltage (CNT), from the exterior.

The composite video signal is subject to synchronous separation in the module and used to write a video signal accurately on each pixel on the module.

The control circuit receives composite synchronizing signal separated in the video interface circuit, generates clock pulses synchronized with the composite synchronizing signal and gate and source drivers-driving signals, and outputs internal horizontal synchronizing signal (\overline{HSY}), internal vertical synchronizing signal (\overline{VSX}), and polarity inversion signal (FRP).

The voltage level of RGB video signals applied to the liquid crystal layer of each pixel through the source driver IC and TFT is about $3.7 V_{P-P}$ from black to white level. In order to prevent the electro-chemical decomposition of the liquid crystal, it is necessary to apply AC voltage to the liquid crystal. For this purpose, the polarity of the video signals must be alternated. Since the amplification and polarity inversion of the video signals are performed in the video interface circuit in the module using the polarity inversion signal (FRP), composite video signal of $1.0 V_{P-P}$ or standard analog RGB signals of $0.7 V_{P-P}$ may be used for both of the inputs to the module.

Power supplies to this module are 5 V (V_{SH}), 0 V (GND), and $-8 V$ (V_{SL}). Control IC operates on a 0 to 5 V line so that it outputs \overline{HSY} and \overline{VSX} at 0 to 5 V level. Power supplies to the video interface circuit are V_{SH} and V_{SL} .

VSW is used to select composite or RGB video signals. VSW selects composite video signal when it is 'High' or open, and selects RGB signals when it is 'Low'.

BRT, COL, TIN, CNT, and V_{CDC} are adjusted to the optimum value on shipping.

The module contains backlight (hot cathode fluorescent tubes) but not a driving circuit for the backlight. Therefore, it is necessary to install a DC/AC inverter for driving the fluorescent tubes.

Standard DC/AC inverter (Model name: LQ0J06) is available as an option.

In addition, the backlight of the module is designed to be replaceable, and the backlight unit (Model name: LQ0B01) is available as a service part for the replacement.

EXAMPLE OF TFT-LCD TV

Figure 15 shows a block diagram example of the TFT-LCD module applied to a TV set. The block enclosed by the dotted line is the TFT-LCD module. Other signal-processing systems are the same as those in ordinary CRT-TV.

The following seven signals must be supplied to this module from the exterior:

- Composite video signal: VBS
- Standard analog RGB video signals
- Signal for selecting input video signals: VSW
- DC bias voltage of common electrode driving signal: V_{CDC}
- Brightness adjusting DC voltage: BRT
- Color gain adjusting DC voltage: COL
- Tint adjusting DC voltage: TIN

The following two signals are output from this module to the exterior:

- Internal horizontal synchronizing signal: \overline{HSY}
- Internal vertical synchronizing signal: \overline{VSX}

When this module is applied to a TV set, for example, \overline{HSY} and \overline{VSX} are used to display selected channel number and characters on the screen.

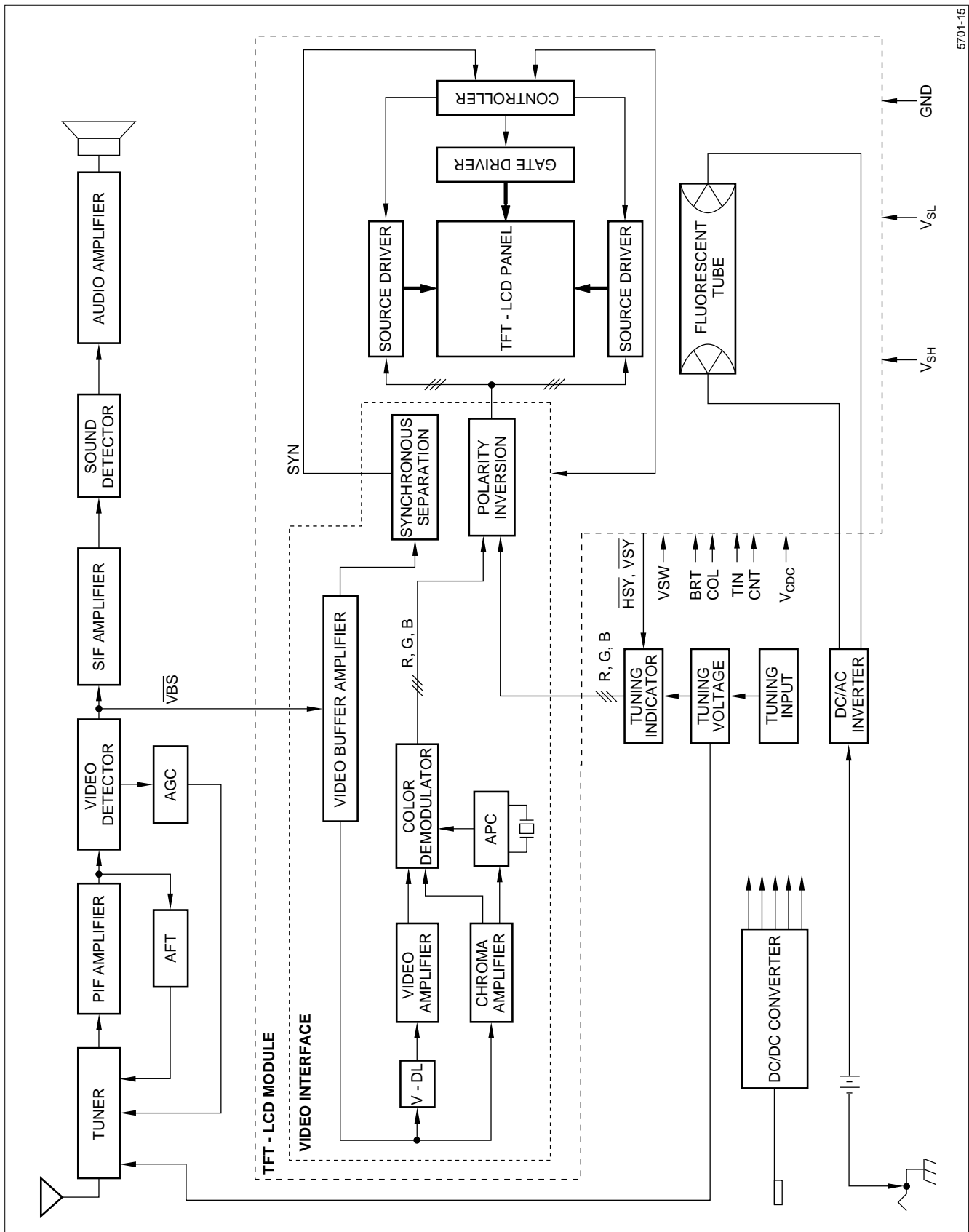

5701-15

Figure 15. Block Diagram of TFT-LCD TV Set

ADJUSTING METHOD OF OPTIMUM COMMON ELECTRODE DC BIAS VOLTAGE

To obtain optimum DC bias voltage of common electrode driving signal (V_{CDC}), photoelectric devices are very effective, and the accuracy is within 0.1 V. (In a visual examination method, the accuracy is about 0.5 V because of the difference among individuals.)

To gain optimum common electrode DC bias voltage, there are two methods which use photoelectric devices. The value of optimum DC bias voltage is the same in both methods:

- Measurement of Flicker: DC bias voltage is adjusted to minimize 60 Hz (30 Hz) flicker.
- Measurement of Contrast: DC bias voltage is adjusted so as to minimize the photoelectric output voltage.

Measurement of Flicker

Photoelectric output voltage is measured by an oscilloscope in a system similar to that shown in Figure 16.

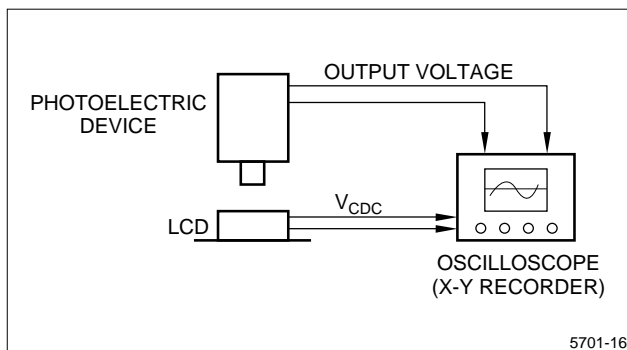

Figure 16. Measurement System

DC bias voltage must be adjusted to minimize the 60 Hz (30 Hz) flicker with DC bias voltage changing slowly (Figure 17).

Measurement of Contrast

Photoelectric output voltage is measured by oscilloscope or X-Y recorder by using the system in Figure 16. Common electrode DC bias voltage must be adjusted to minimize the photoelectric output voltage with DC bias voltage changing slowly (Figure 18).

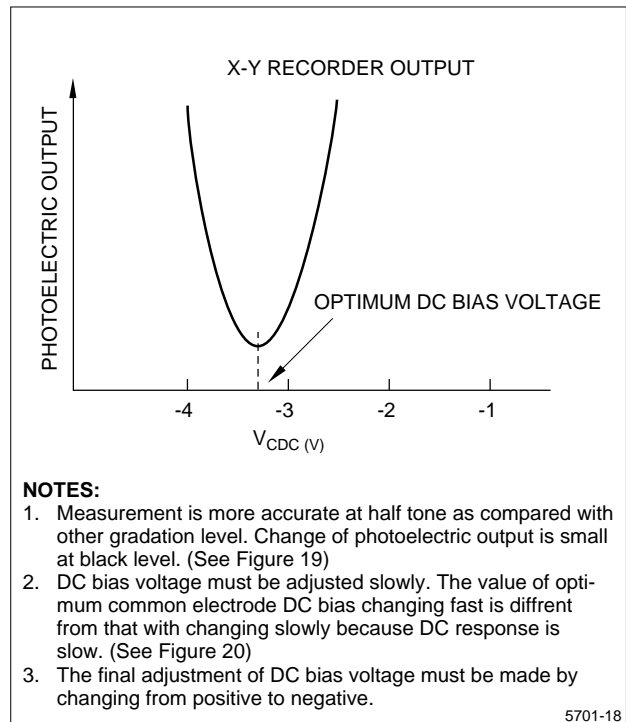

Figure 18. Optimum Common Electrode DC Bias Voltage By Measurement of Contrast

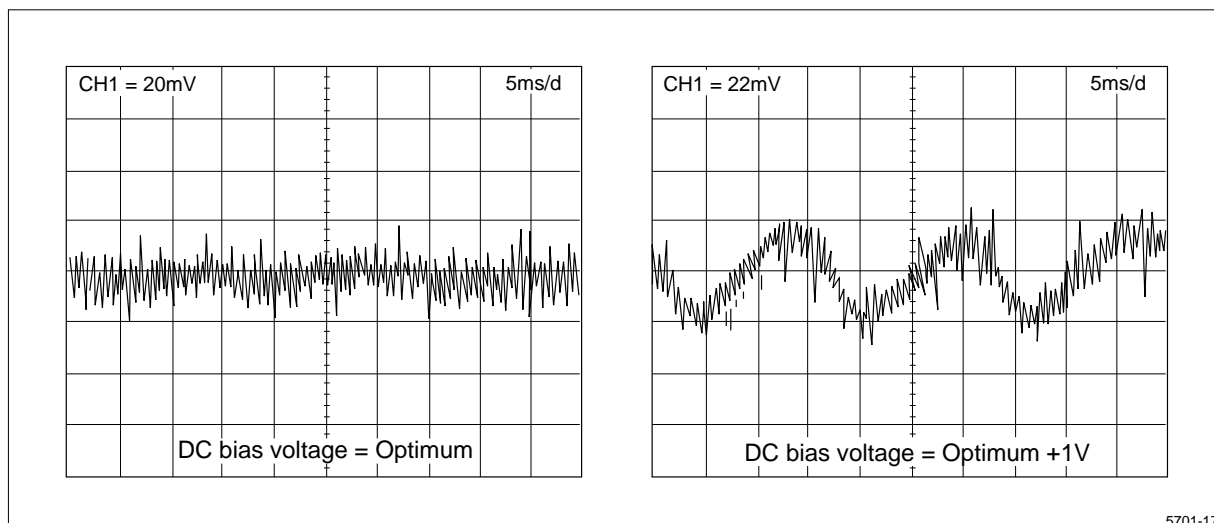

Figure 17. Waveform of Flicker

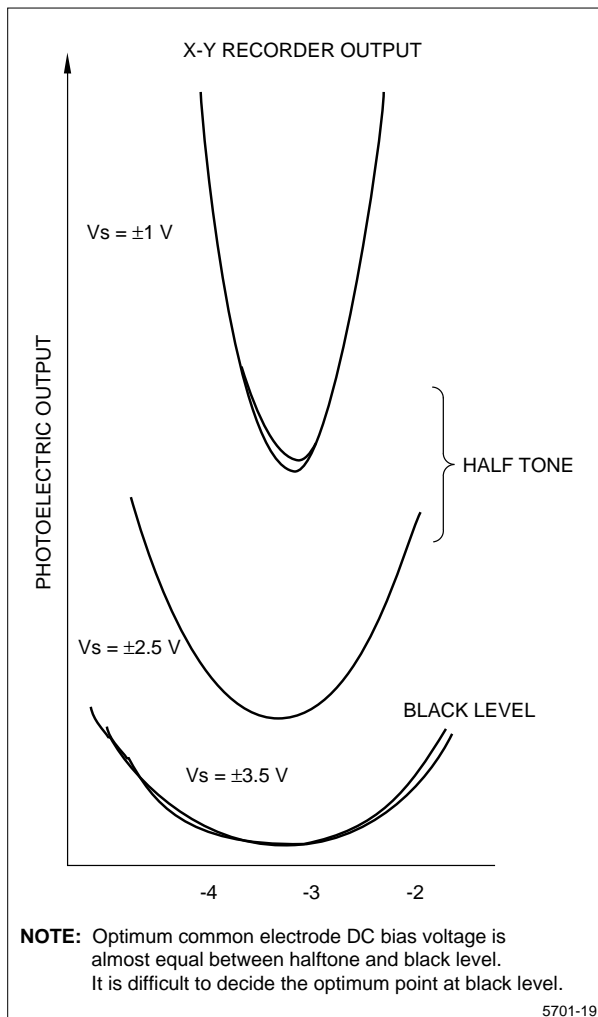

Figure 19. Relation Between Gradation Level and DC Bias Voltage

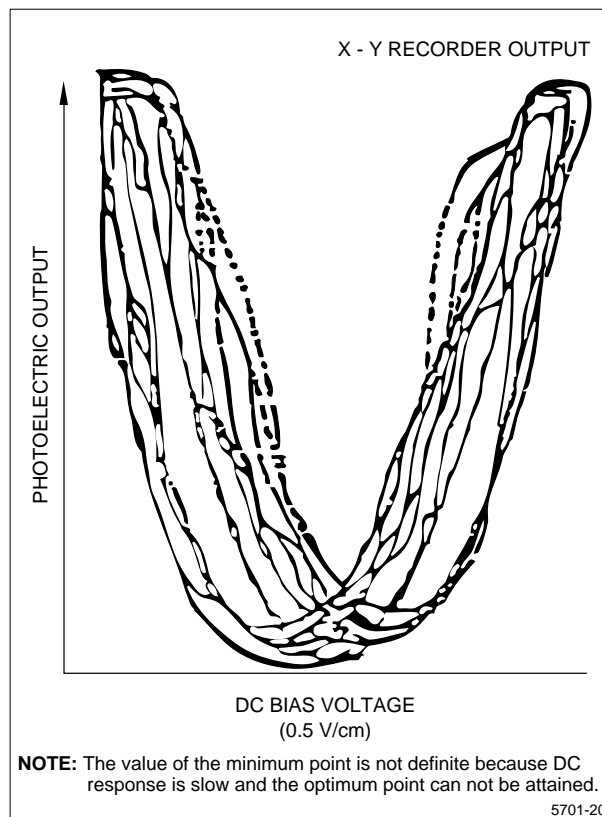
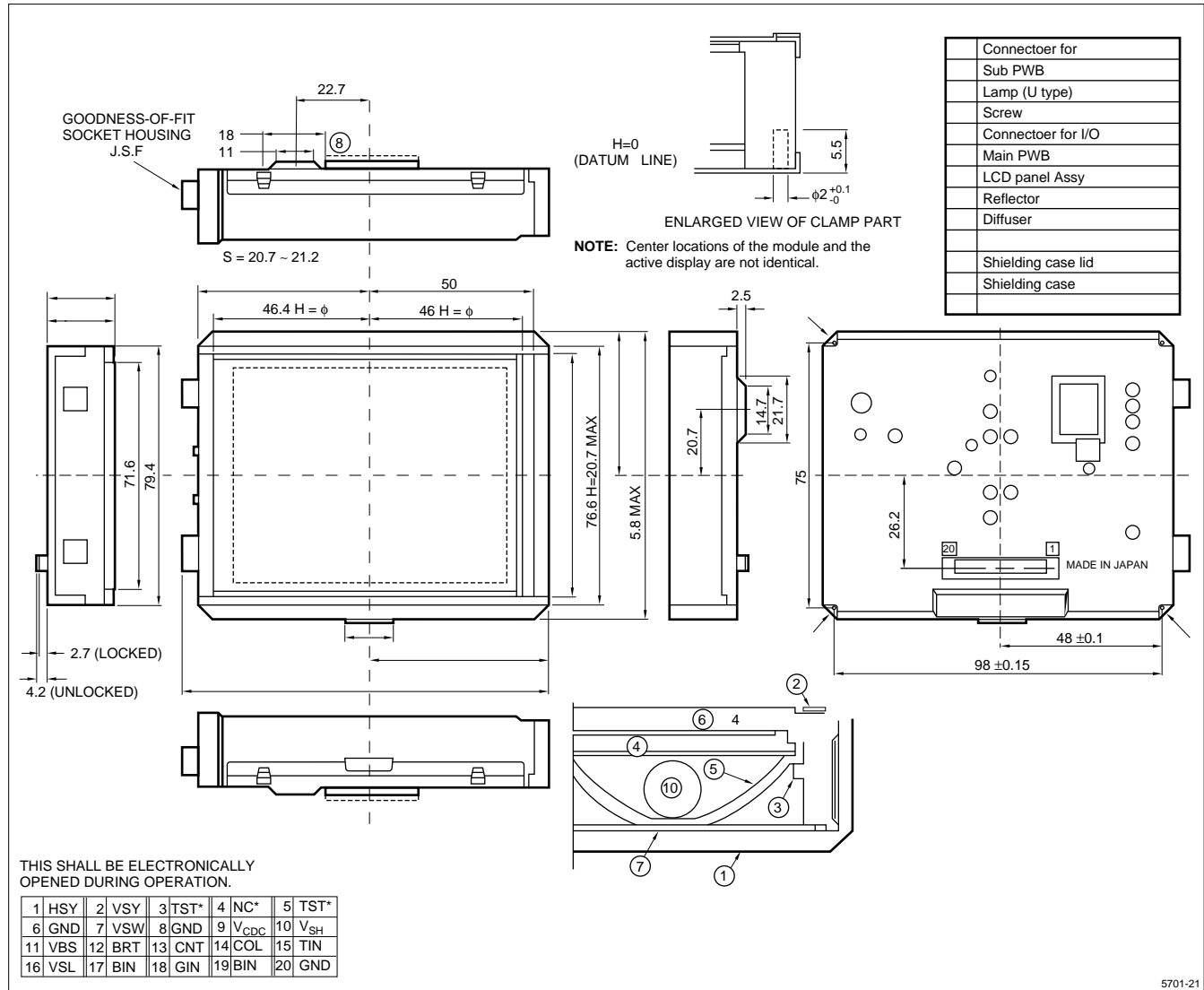

Figure 20. Output Voltage With DC Bias Voltage Changing Fast

OUTLINE DIMENSIONS



5701-21